



# ENCARDIO RITE

ONE STOP MONITORING SOLUTIONS | HYDROLOGY | GEOTECHNICAL | STRUCTURAL | GEODETIC  
Over 50 years of excellence through ingenuity

---

**USERS' MANUAL**

---

## SEEPAGE MONITORING SYSTEM

MODEL **ESM-11V**



Doc. # WI 6002.96 Rev. 01 | Sept 10

---

**ENCARDIO-RITE ELECTRONICS PVT. LTD.**

A-7, Industrial Estate, Talkatora Road Lucknow, UP - 226011, India | P: +91 522 2661039-42 | Email: [geotech@encardio.com](mailto:geotech@encardio.com) | [www.encardio.com](http://www.encardio.com)

International: UAE | Qatar | Bahrain | Bhutan | Europe | USA

India: Lucknow | Delhi | Kolkata | Mumbai | Chennai | Bangalore | Hyderabad | J&K

## Contents

<b>1</b>	<b>INTRODUCTION</b>	<b>1</b>
1.1	Instrument and its accessories	1
1.2	Conventions used in this manual	1
1.3	How to use this manual	2
<b>2</b>	<b>VIBRATING WIRE SEEPAGE MONITOR</b>	<b>3</b>
2.1	Operating principle	3
2.2	General description	3
2.2.1	Seepage monitor	3
2.2.2	Wall mounting plate with junction box and moisture trap assembly	3
2.3	Taking readings with the model EDI-54V vibrating wire indicator	4
2.4	Sample Test Certificate Format	5
<b>3</b>	<b>INSTALLATION PROCEDURE</b>	<b>6</b>
3.1	Checking sensor before installation	6
3.2	Installation	6
3.3	Connection to junction box with moisture trap assembly	8
3.4	Points to be considered while installation of V notch	9
3.5	Taking readings	9
3.6	Establishing gage zero	10
3.7	Calculation of flow rate	10
<b>4</b>	<b>THERMISTOR - TEMPERATURE RESISTANCE CORRELATION</b>	<b>11</b>
4.1	Measurement of temperature	12
4.2	Temperature correction	12
4.3	Polynomial linearity correction	12
<b>5</b>	<b>WARRANTY</b>	<b>13</b>

## 1 INTRODUCTION

---

Quantity of water seeping through, around or under a dam is of great importance in analysing structural behaviour of a dam. For measuring seepage, the drain water is taken through collection channel(s) for discharge into the downstream of dam. The collection channel/channels are terminated in a collection chamber where the discharge is accurately measured with a 'V' notch and a water level measurement system.

In order to measure discharge over the weir accurately, the head over the weir is measured with a vibrating wire level sensor. Generally, to avoid water level variations caused by waves, turbulence or vibration, the head water level should be measured in a stilling well-constructed upstream of the weir in the collection channel.

The Encardio-rite model ESM-11V seepage monitoring system is designed for precision measurement and monitoring of water level in weirs, tanks and reservoirs and seepage in dams. It basically consists of a submersible cylinder suspended from a vibrating wire load transducer. The component parts are enclosed in a perforated PVC pipe.

The Encardio-rite seepage monitoring system can be supplied with a stainless steel V-notch weir, if ordered separately, to monitor rate of flow of water.

The submersible cylinder is partially submerged in water whose level is to be monitored. Any change in water level changes the buoyancy on the cylinder, which is measured by the vibrating wire load transducer.

Encardio-rite model EDI-54V vibrating wire readout can be used to measure the frequency output of the vibrating wire seepage monitoring device. The EDI-54V can be configured to automatically calculate and display the liquid level in the sensors directly in engineering units (in this case in millimetres). For continuous monitoring of the vibrating wire level sensors a data acquisition system like Encardio-rite model EDAS-10 data acquisition system can be used.

Since the sensor is vibrating wire type and has frequency output, data can be transmitted over long lengths of cable. The vibrating wire sensor has a vented signal cable, the vent tube of which is terminated in a moisture trap of a desiccant chamber. The vent being open to atmosphere helps to compensate the barometric fluctuations automatically.

### 1.1 Instrument and its accessories

- Vibrating wire load transducer. It is supplied with requisite length of CS-0501 four core vented cable attached to it.
- Float
- Perforated PVC tube with top cap and cable gland to fix transducer
- Wall mounting plate with junction box and moisture trap assembly
- V-notch (to be separately ordered)

### 1.2 Conventions used in this manual

**WARNING!** Warning messages calls attention to a procedure or practice, that if not properly followed could possibly cause personal injury.

**CAUTION:** Caution messages calls attention to a procedure or practice, that if not properly followed may result in loss of data or damage to equipment.

**NOTE:** Note contains important information and is set off from regular text to draw the users' attention.

This users' manual is intended to provide you with sufficient information for making optimum use of vibrating wire seepage monitoring system in your application.

To make this manual more useful we invite your valuable comments and suggestions regarding any additions or enhancements. We also request you to please let us know of any errors that you may find while going through this manual.

### **1.3 How to use this manual**

The manual is divided into a number of sections. Each section contains a specific type of information. The list given below tells you where to look for in this manual if you need some specific information.

*For understanding the working principle of vibrating wire Seepage Monitoring System:* See § 2.1 'Operating principle'.

*For test certificate:* See § 2.4 'Sample test certificate format'.

*For essential tools and accessories:* See § 3 'Tools and accessories required for installation'.

*For installation of Seepage Monitoring System:* See § 4 'Installation procedure'.

*For evaluating thermistor data:* See § 5 'Thermistor - temperature resistance correlation'.

## 2 VIBRATING WIRE SEEPAGE MONITOR

---

### 2.1 Operating principle

The seepage monitor is based on the principle of measurement of apparent weight of a hollow metal float that always remains partially submerged in liquid inside the seepage monitoring system. As the level of liquid in the seepage monitor goes up or down there is a corresponding change in the apparent weight of the float in accordance with the law of buoyancy. A vibrating wire load transducer (force transducer) is used to measure the apparent weight of the float.

The vibrating wire load transducer essentially consists of a stretched magnetic wire that carries the entire load of the float. The transducer has two opposing electromagnet coils around the middle of the stretched wire. Initially a plucking signal is applied to the coils which sets the vibrating wire vibrating at its natural (also known as resonant) frequency. The vibrating wire induces a corresponding AC voltage across the magnet coils which can be measured to determine the frequency of the vibrating wire. As the apparent load on the load transducer increases or decreases the frequency of the output signal from the vibrating wire load transducer changes accordingly.

### 2.2 General description

#### 2.2.1 Seepage monitor

The seepage monitor basically consists of a perforated PVC pipe, with a vibrating wire load transducer fixed from the top of it. A smaller diameter cylindrical stainless steel float is suspended from this load transducer. The weight of this float is so adjusted that it always remains partially submerged in the liquid contained in the bottom vessel.

The shielded cable CS-0501 has a vent tube running from inside the sensor to the outside atmosphere ensuring that sensor reading is unaffected by change in barometric pressure. The end of the vent tube terminates into a moisture trap assembly described below thus preventing any moisture from migrating into the vent tube. Please ensure that the desiccant in the moisture trap is changed frequently as and when required.

#### 2.2.2 Wall mounting plate with junction box and moisture trap assembly

The wall mounting plate has two clamps into which the moisture trap assembly can be snapped. The moisture trap assembly contains two plastic desiccant capsules with blue colour desiccant inside them. Desiccant needs changing when it becomes colourless. The leads from the CS-0501 four core vented cable are terminated in the junction box mounted on the wall mounting plate from where a standard shielded four core cable can be used.

Use two Hilti expandable fasteners HPS-5x25 or equivalent to secure the wall mounting plate vertically on any vertical surface like a wall.

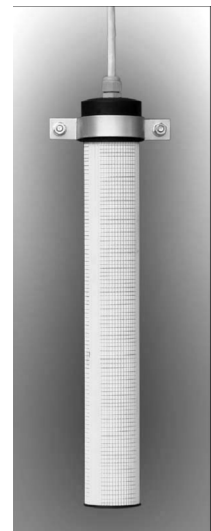

Figure 1

### 2.3 Taking readings with the model EDI-54V vibrating wire indicator

The model EDI-54V vibrating wire indicator (figure 2) is a microprocessor-based read-out unit for use with Encardio-rite's range of vibrating wire sensors. It can display the measured frequency in terms of time period, frequency, frequency squared or the value of measured parameter directly in proper engineering units. It uses a smartphone with Android OS as readout having a large display with a capacitive touch screen which makes it easy to read the VW sensor.

The EDI-54V vibrating wire indicator can store calibration coefficients from 10,000 vibrating wire sensors so that the value of the measured parameter from these sensors can be shown directly in proper engineering units. For transducers with built-in interchangeable thermistor, it can also display the temperature of the transducer directly in degree Centigrade.

The vibrating wire indicator has an internal non-volatile memory with sufficient capacity to store about 525,000 readings from any of the programmed sensors. Each reading is stamped with the date and time the measurement was taken.

Refer instruction manual WI-6002.112 of model EDI-54V for entering the transducer calibration coefficients. The gage factor of the model ESM-11V seepage monitoring sensor is given in the test certificate provided with every supply.

An internal 6 V 4 Ah rechargeable sealed maintenance-free battery is used to provide power to the vibrating wire indicator. A battery charger is provided to charge the internal battery which operates from 90 V to 270 V AC 50 or 60 Hz V AC mains. A fully discharged battery takes around 6 hours to get fully charged. The indicator uses a smartphone as a readout that has its own internal sealed rechargeable Li-ion maintenance battery as a power source. A separate battery charger/adaptor unit for the smartphone, operating from universal AC mains supply is supplied with each EDI-54V indicator unit.

The EDI-54V vibrating wire indicator is housed in an impact resistant plastic moulded housing with weatherproof connectors for making connections to the vibrating wire transducer and the battery charger.



Fig 2 – Vibrating wire indicator

## 2.4 Sample Test Certificate Format

### TEST CERTIFICATE

Customer  
 P.O.no.  
 Instrument Vibrating wire load transducer for seepage monitor  
 Model EML-10V Date 05.02.2010  
 Sensor serial number XXXXX Temperature 32°C  
 Range 150 mm  
 Float serial number XXXXX  
 Float detail a) Weight (kg):  
 b) Length (mm):  
 c) Outer diameter (mm):

Change in water head (mm)	Observed value (Digit)				Average (Digit)	End Point	Poly
	Increasing	Decreasing	Increasing	Decreasing		Fit	Fit
	C-1	C-2	C-3	(C1+C3)/2	(mm)	(mm)	
0.0	11019.9	11012.2	11012.2	11016.1	0.00	0.01	
30.0	10267.5	10273.6	10271.6	10269.5	29.93	29.84	
60.0	9507.8	9511.1	9511.3	9509.6	60.40	60.27	
90.0	8761.9	8770.2	8775.7	8768.8	90.11	89.99	
120.0	8023.5	8035.8	8033.5	8028.5	119.79	119.76	
150.0	7276.8	7276.8	7273.2	7275.0	150.00	150.12	
				Error (%FS)	0.27	0.18	

Digit  $f^2 / 1000$   
 Linear gage factor (G) 4.0095E-02 mm/digit  
 (Use gage factor with minus sign with our read out unit Model: EDI-54V)

Polynomial constants  
 A=5.6158E-08 B=-4.1150E-02 C= 4.4651E+02

Height of liquid level in sensor chamber "H" is calculated with the following equation:

Linear  $H \text{ (mm)} = G (R0 - R1)$

Polynomial  $H \text{ (mm)} = A(R1)^2 + B(R1) + C$

R1 = current reading & R0 is initial reading in digit.

Zero reference (initial position) in the field must be established by recording the initial reading R0 (digit), temperature T0 (°C) and atmospheric pressure S0 (MPa). In case polynomial constants are used, determine value of constant C as per § 4.3.

**Note** Zero reading given in above calibration chart is taken when ~5 mm of float length is submerged in water

Pin configuration/wiring code:

Red & black: Signal Green & white: Thermistor

Checked by \_\_\_\_\_ Tested by \_\_\_\_\_

### 3 INSTALLATION PROCEDURE

#### 3.1 Checking sensor before installation

- Vibrating wire sensor is provided with a 4-core cable. Resistance between red and black lead should lie between 120-150 Ohm.
- Connect sensor red, black, green & white lead to flying clips of portable readout unit model EDI-54V. Switch on readout unit.
- Press FREQ key to check sensor frequency. A valid frequency reading means that the sensor is functioning properly

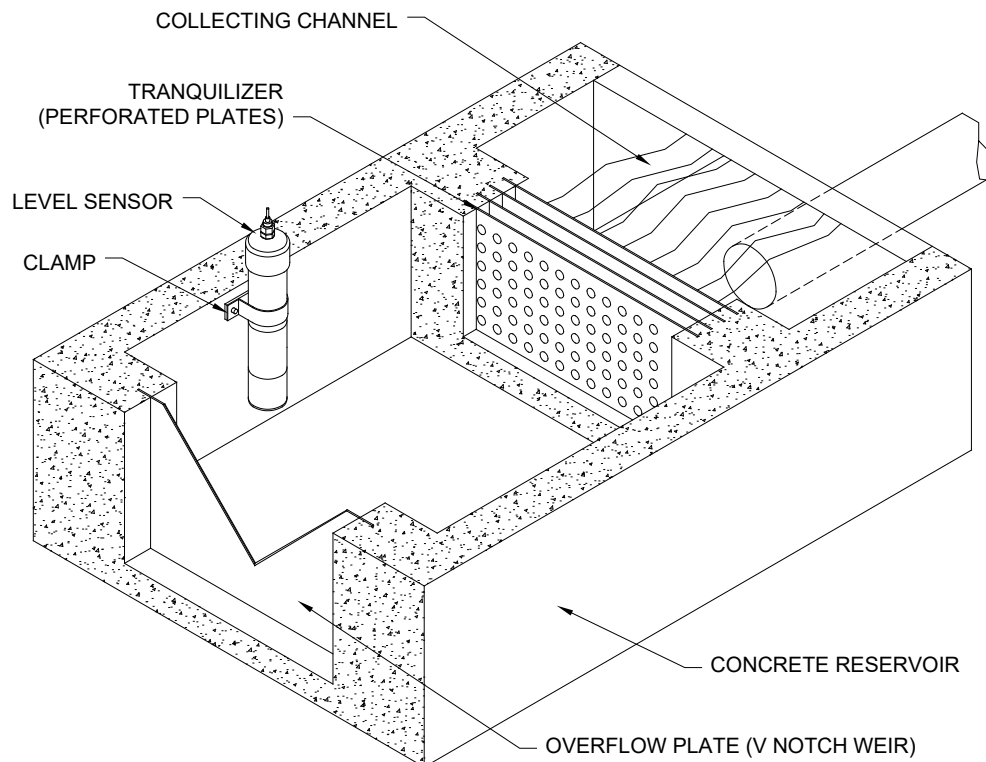

Figure 3– Typical layout

#### 3.2 Installation

- Fix 'V' notch in the concrete reservoir, generally as shown in figure 1.
- The perforated PVC pipe of the sensor assembly is provided with two ring markings (for minimum and maximum water level as shown in figure 3). The sensor assembly will have to be mounted such that expected maximum and minimum water level is always between these marked rings. Sensor assembly should be located at a distance of 4-5 times the maximum head upstream over the bottom of the V notch at any time.
- Mark position of holes for expandable anchors (centre distance given in figure 2). Drill 8 mm diameter holes, 75 mm deep to fix the stilling well with clamps using Hilti HSTR-M8 x 75/10 mm expandable anchors or equivalent, as shown in figure 3.

**NOTE:** The sensor assembly should be located at a sufficient distance upstream from the weir because the flow at the brink of the weir is sloping down and curvilinear in nature. The depth at the drop is therefore not equal to the critical depth as computed by the principle based on parallel flow. The location of the head measurement section will be satisfactory if it is located at a distance of 4-5 times the maximum head over the bottom of the V notch at any time.



**CAUTION:** It is important that the sensor assembly is mounted in a vertical position, to prevent any friction which may be caused from the weight rubbing against the well. This may influence the transducer reading.

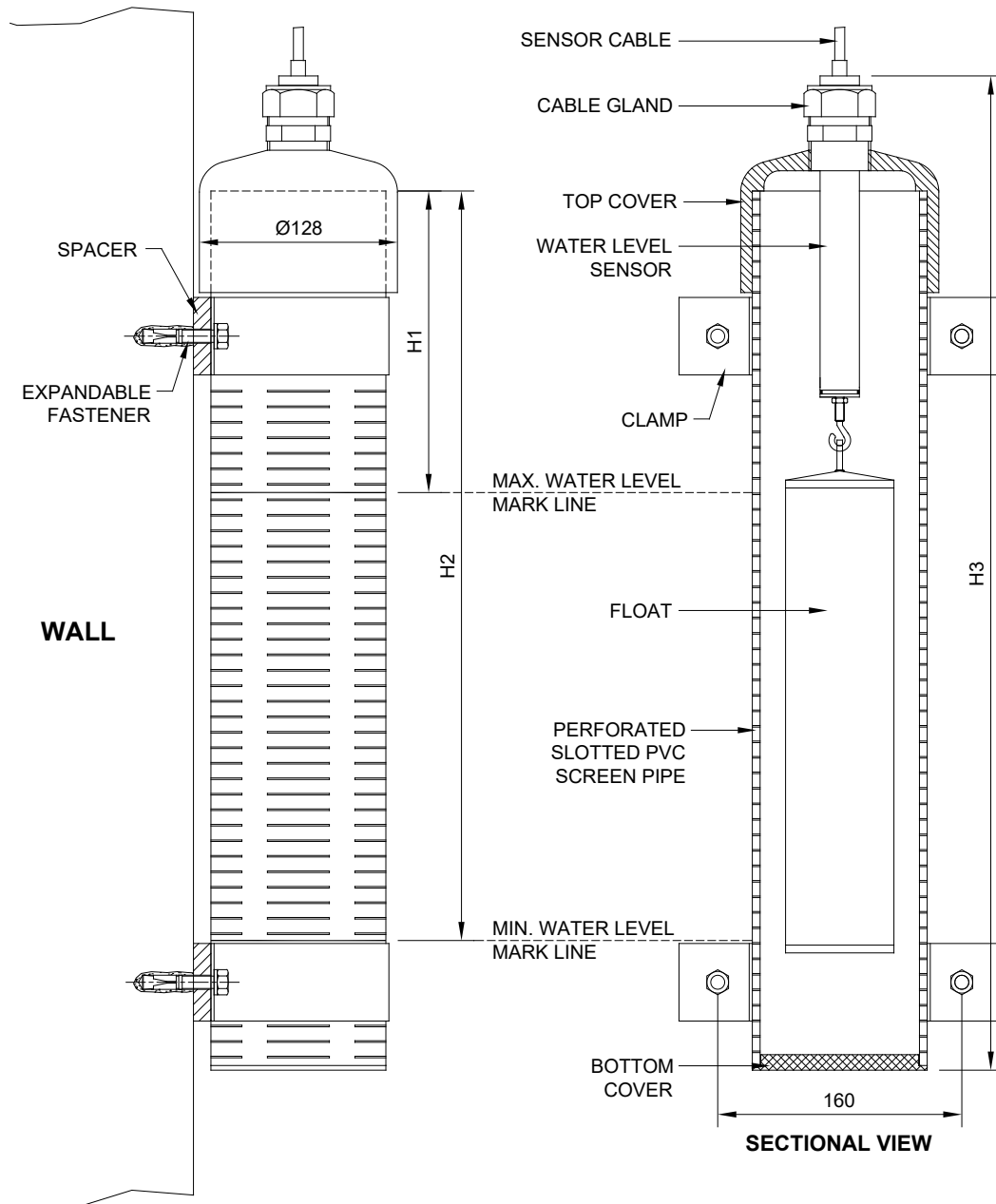

**Figure 4 – Sensor assembly**

Range (mm)	H1 (mm)	H2 (mm)	H3 (mm)	Perforated tube length (mm)
150	198	342	520	450
300	198	492	670	600
600	198	792	970	900

- Mount load transducer to top cap of perforated PVC pipe using the cable gland tightly.
- Unscrew the nut on the hook holder stud of the load transducer (marked N1 in the figure alongside) by two complete turns.
- Gently suspend the submersible cylinder from the vibrating wire load transducer with the help of the hook as shown in figure 5.

**CAUTION:** The seepage monitoring device uses a high precision vibrating wire transducer that is very fragile. The sensor is supplied in semi assembled state and has to be finally assembled at site before fixing. Great caution should be exercised while assembling or fixing the sensor to avoid any damage to the load transducer.

- Carefully and slowly lower the load transducer housing (with float) inside the perforated PVC pipe and fix the top cap to the perforated PVC pipe.

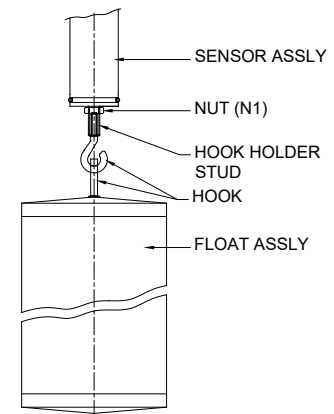
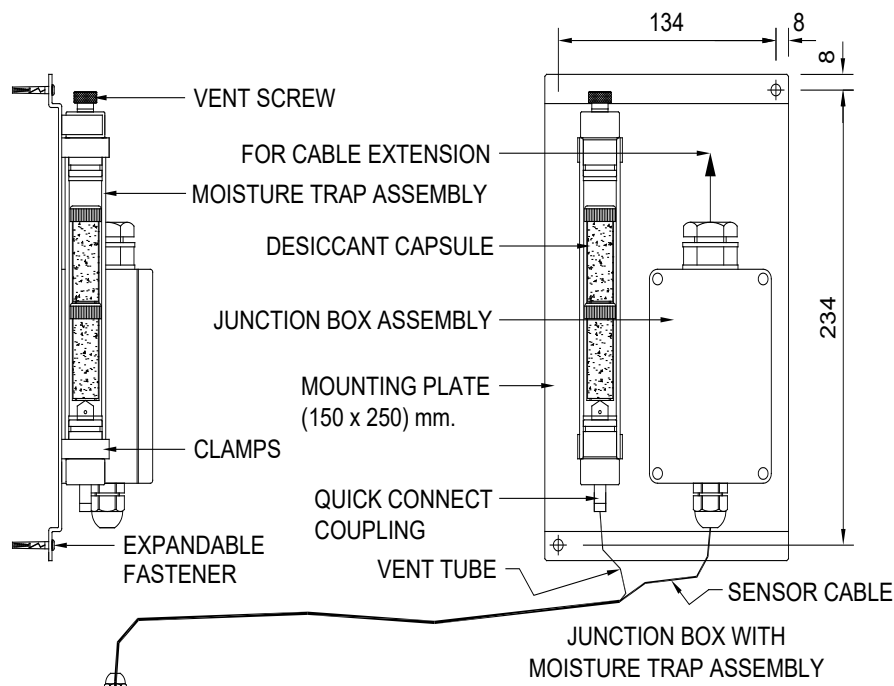

**Figure 5**

### 3.3 Connection to junction box with moisture trap assembly

The vibrating wire load transducer is vented to atmosphere to ensure that air pressure both inside and outside the capsule are same so that any change in atmospheric pressure does not affect the reading of the transducer. The load transducer vent tube is connected to a desiccant container so that only dry air can enter the transducer vent line. Moisture content in air in the transducer vent line can, in course of time, coalesce to form water droplets and can damage the inside of transducer.

- Fix wall mounting plate on a nearby vertical surface by means of the two Hilti expandable fasteners HPS 5x25 or equivalent provided (see figure 6).



**Figure 6**

- Check colour of desiccant in desiccant capsule. It should be blue. It needs changing before it becomes colourless.
- Remove cap from cable vent tube and plug from quick connect coupling at bottom of moisture trap assembly. Insert cable capillary tube in quick connect coupling to make a secure connection.

- Remove junction box cover. Terminate leads from CS-0501 four core vented cable in the junction box from where a standard shielded four core cable can be used. Black and red leads are from the vibrating wire gage and green and white leads are from the thermistor for measurement of temperature. Replace junction box cover.
- Turn vent screw at top of moisture trap assembly to open it to the atmosphere. Ensure connectivity between the vent tube running from inside the load transducer to the outside atmosphere such that load transducer reading is unaffected by any change in barometric pressure (there should not be any sharp bend).
- Connect the load transducer lead to the 4-core cable from instrumentation monitoring room using junction box supplied with the system.
- Check load transducer operation from the other end of the four core cable (in instrumentation room) by a vibrating wire readout unit (Encardio-rite model EDI-54V). See that the reading is stable and corresponds to the reading obtained at the junction box.

### 3.4 Points to be considered while installation of V notch

- Use sealing compound to make junction box watertight.
- The upstream face of the weir plate should be smooth and in a vertical plane perpendicular to the axis of the channel.
- The distance from the bottom of the approach channel (weir pool) to the crest should preferably be at least twice the depth of water above the crest, but not less than 30 cm.
- The distance from the sides of the weir to the sides of the approach channel should preferably be at least twice the depth of water above the crest, but not less than 30 cm.
- The overflow sheet (nappe) should touch only the upstream edges of the notch.
- The maximum water level in downstream pool should be at least 6 cm below crest elevation.
- The head on the weir should be taken as the difference in elevation between the crest and the weir surface at a point upstream from the weir.

### 3.5 Taking readings

- Connect the red and black VW sensor output leads to the VW input leads of the EDI-54V indicator. With indicator powered on, press the FREQ2 key on the indicator to get frequency<sup>2</sup> readings of the sensor in terms of Hz<sup>2</sup>.
- The Hz<sup>2</sup> readings have to be converted to corresponding water head in mm for calculation of flow rate. For this the vw sensor gage factor and initial gage zero readings are required. The gage factor is supplied on the test certificates that accompany each sensor shipped from factory. However the gage factor is mentioned in terms of digits where 1 digit = 1000 Hz<sup>2</sup>. The frequency<sup>2</sup> reading on the EDI-54V is shown with a multiplier E+3 (i.e. x 10<sup>3</sup>). Simply ignoring this multiplier while noting down the readings yield the value in digits. For example, if the display shows frequency<sup>2</sup> value as 7869.3E+3, the value in digits would be 7869.3.
- To find the height of water level over the crest, the following equation is used:
- $h = G \times (R_1 - R_0)$
- where,  $R_0$  is gage zero reading in digits,  $R_1$  is current reading of the vibrating wire load transducer in digits, and  $G$  is the gage factor in terms of mm/digit.  $R_0$  has to be established in the field after installation of the vw sensor and is explained in the following section.

- The gage zero (also known as initial reading) and the gage factor can be entered for each sensor individually in the EDI-54V so that the measured water head is displayed directly in mm. Please refer EDI-54V User's Manual for more details.

### 3.6 Establishing gage zero

- The weir head datum or gage zero should be determined with great care. The gage zero corresponds to the water level in the approach channel that is at the same elevation as the vertex (crest) of the 'V' notch.
- A coarse method of determining gage zero is to draw water in the approach channel down to the apparent crest (notch) level. However, this method does not provide sufficient accuracy due to effect of surface tension.
- An acceptable method of measuring gage zero is to draw water in the approach channel a little below the crest. The difference between the water level and the crest in mm (say 'd') is then measured with a height gage. The gauge zero can then be found by adding the height difference to the level currently shown by the level sensor.
- Note down the water level as measured by the sensor by using EDI-54V indicator. Say the reading is  $R_z$ .
- Calculate  $R_0$ , as described in the previous section, as follows:
- $R_0 = R_z + (d/G)$ ,
- where, G is gage factor of the vw sensor in mm/digits.
- The obtained value of  $R_0$  is known as the gage zero and is also used as the initial reading for calculation of water head by the EDI-54V indicator.

### 3.7 Calculation of flow rate

- The seepage water flow rate through the weir can be calculated using the following equation (when using 90° V-notch):

$$Q = 0.024 \times C_e \times h^{5/2}$$

where, Q is flow rate in litre per second, 'h' is head of water above the crest (vertex of notch) in cm, and  $C_e$  is a correction factor, known as coefficient of discharge. The value of  $C_e$  to be used can be found in published authoritative literature on the subject and is beyond the scope of this user's manual. However, a gross estimate of the flow rate can be obtained by using a value of  $C_e = 0.6$ .

#### 4 THERMISTOR - TEMPERATURE RESISTANCE CORRELATION

**Thermistor type** Dale 1C3001-B3

##### Temperature resistance equation

$$T = 1/[A + B(\text{LnR}) + C(\text{LnR})^3] - 273.2 \text{ } ^\circ\text{C}$$

T = temperature in  $^\circ\text{C}$

LnR = Natural log of thermistor resistance

A =  $1.4051 \times 10^{-3}$

B =  $2.369 \times 10^{-4}$

C =  $1.019 \times 10^{-7}$

Ohm	Temp. $^\circ\text{C}$	Ohm	Temp. $^\circ\text{C}$	Ohm	Temp. $^\circ\text{C}$
201.1k	-50	16.60K	-10	2417	+30
187.3K	-49	15.72K	-9	2317	31
174.5K	-48	14.90K	-8	2221	32
162.7K	-47	14.12K	-7	2130	33
151.7K	-46	13.39k	-6	2042	34
141.6K	-45	12.70K	-5	1959	35
132.2K	-44	12.05K	-4	1880	36
123.5K	-43	11.44K	-3	1805	37
115.4K	-12	10.86K	-2	1733	38
107.9K	-41	10.31K	-1	1664	39
101.0K	-40	9796	0	1598	40
94.48K	-39	9310	+1	1535	41
88.46K	-38	8851	2	1475	42
82.87K	-37	8417	3	1418	43
77.66K	-36	8006	4	1363	44
72.81K	-35	7618	5	1310	45
68.30K	-34	7252	6	1260	46
64.09K	-33	6905	7	1212	47
60.17K	-32	6576	8	1167	48
56.51K	-31	6265	9	1123	49
53.10K	-30	5971	10	1081	50
49.91K	-29	5692	11	1040	51
46.94K	-28	5427	12	1002	52
44.16K	-27	5177	13	965.0	53
41.56k	-26	4939	14	929.6	54
39.13K	-25	4714	15	895.8	55
36.86K	-24	4500	16	863.3	56
34.73K	-23	4297	17	832.2	57
32.74K	-22	4105	18	802.3	58
30.87K	-21	3922	19	773.7	59
29.13K	-20	3748	20	746.3	60
27.49K	-19	3583	21	719.9	61
25.95K	-18	3426	22	694.7	62
24.51K	-17	3277	23	670.4	63
23.16K	-16	3135	24	647.1	64
21.89K	-15	3000	25	624.7	65
20.70K	-14	2872	26	603.3	66
19.58K	-13	2750	27	582.6	67
18.52K	-12	2633	28	562.8	68
17.53K	-11	2523	29	525.4	70

#### 4.1 Measurement of temperature

Thermistor for temperature measurement is provided in all centre hole load cells. The thermistor gives a varying resistance output related to the temperature. The thermistor is connected between the green and white leads. The resistance can be measured with an Ohmmeter. The cable resistance may be subtracted from the Ohmmeter reading to get the correct thermistor resistance. However the effect is small and is usually ignored.

The Encardio-rite model EDI-54V read-out unit gives the temperature from the thermistor reading directly in engineering units.

#### 4.2 Temperature correction

Each vibrating wire sensor is individually calibrated for temperature zero drift. In case a 'level - temperature variation' correlation is required, the correction for the temperature effect on the sensor can be made by making use of the temperature zero shift factor (K) provided in the test certificate (see § 2.4) and substituting it in the following equation:

$$P_{\text{correction}} = (\text{current temperature} - \text{initial temperature}) \times K$$

The temperature correction value is added to the height read from the EDI-54V read-out.

#### 4.3 Polynomial linearity correction

Refer to § 2.4 - test certificate for vibrating wire load transducer. Polynomial constants 'A', 'B', and 'C' in test certificate are determined at ambient barometric pressure and temperature at time of calibration. The value of constant 'C' given in test certificate would have been different had barometric pressure or temperature been different at time of calibration.

For example in § 2.4 - test certificate, the initial average reading in digits in test certificate at time of calibration is 11016.1. This initial zero reading at time of installation would have slightly changed due to difference in barometric pressure/temperature or due to rough handling during transportation or installation. For example, let initial zero reading (§ 2.4) at time of installation be 11025 digits. The constant 'C' will then have to be reworked as follows by setting the pore pressure 'P' at zero in the polynomial equation:

$$P = A (R_1)^2 + B(R_1) + C \text{ MPa}$$

$$\text{or } 0 = -5.6158\text{E-}08 \times (11025)^2 - 4.1150\text{E-}02 \times (11025) + C$$

$$\text{or } C = 8.983\text{E+}02$$

Instead of  $C = 4.4651\text{E+}02$  given in the test certificate, use the value  $C = 4.4685\text{E+}02$  to get the water level reading with polynomial linearity correction

## 5 WARRANTY

---

The Company warrants its products against defective workmanship or material for a period of 12 months from date of receipt or 13 months from date of dispatch from the factory, whichever is earlier. The warranty is however void in case the product shows evidence of being tampered with or shows evidence of damage due to excessive heat, moisture, corrosion, vibration or improper use, application, specifications or other operating conditions not in control of Encardio-Rite. The warranty is limited to free repair/replacement of the product/parts with manufacturing defects only and does not cover products/parts worn out due to normal wear and tear or damaged due to mishandling or improper installation. This includes fuses and batteries

If any of the products does not function or functions improperly, it should be returned freight prepaid to the factory for our evaluation. In case it is found defective, it will be replaced/repaired free of cost.

A range of technical/scientific instruments are manufactured by Encardio-rite, the improper use of which is potentially dangerous. Only qualified personnel should install or use the instruments. Installation personnel must have a background of good installation practices as intricacies involved in installation are such that even if a single essential but apparently minor requirement is ignored or overlooked, the most reliable of instruments will be rendered useless.

The warranty is limited to as stated herein. Encardio-rite is not responsible for any consequential damages experienced by the user. There are no other warranties, expressed or implied, including but not limited to the implied warranties of merchantability and of fitness for a particular purpose. Encardio-rite is not responsible for any direct, indirect, incidental, special or consequential damage or loss caused to other equipment or people that the purchaser may experience as a result of installation or use of the product. The buyer's sole remedy for any breach of this agreement or any warranty by Encardio-rite shall not exceed the purchase price paid by the purchaser to Encardio-rite. Under no circumstances will Encardio-rite reimburse the claimant for loss incurred in removing and/or reinstalling equipment.

A lot of effort has been made and precaution for accuracy taken in preparing instruction manuals and software. However best of instruction manuals and software cannot provide for each and every condition in field that may affect performance of the product. Encardio-rite neither assumes responsibility for any omissions or errors that may appear nor assumes liability for any damage or loss that results from use of Encardio-rite products in accordance with the information contained in the manuals or software.

Products described in Encardio-rite's catalogs are subject to modification and improvement as dictated by subsequent developments. Encardio-rite reserves the right to modify, change or improve products, to discontinue them or to add new ones without notice.