

INSTRUMENTATION OF BRIDGES

1. Introduction

The two main characteristics of a bridge that need to be studied are its long-term behaviour under environmental changes and short-term behaviour under traffic loading. In order to study these behaviours and learn from them, geotechnical sensors are carefully located at relevant points on the body of the bridge and around it. Geotechnical instrumentation is used in bridge construction for one or more of the following objectives:

- To verify design parameters and to evaluate performance of new materials and technologies used in bridge construction.
- To verify and control the construction process.
- For performance monitoring and verification.
- For monitoring condition of the bridge and to alert responsible officials in the case of approaching failure.

Advanced technology is available nowadays to perform the above monitoring and verification functions, to improve understanding of the actual loading pattern and to study the corresponding bridge response. It is possible to monitor how effect of loading changes with time as the bridge ages and deteriorates. Geotechnical instruments are usually hidden from view; but the benefits are never out of sight.

The techniques vary from the static measurement of stress, strain, temperature and deformation to several complex dynamic measurements. Static tests can always be performed with known truckloads or hydraulic jacks to confirm monitoring results and to calibrate instruments used in different sections of the bridge. Sensors for geotechnical and structural engineering should ideally have a lifetime comparable with the serviceable age of the structure, which is generally of the order of a few decades. World wide experience with resistive sensing elements, being used earlier, have shown that they are very easily affected by changes in external factors like temperature, humidity, cable length, nearby magnetic or electric fields, etc. The performance of the resistive sensing elements degrade over time and their output leads are prone to noise pick up from nearby electrical activity. These factors make it difficult to get stable and accurate readings from resistive sensors, especially over long periods, though they are very well suited for laboratory applications.

Nowadays most sensors for geotechnical and structural engineering applications are based on the vibrating wire principle. The output from a vibrating wire sensor is in the form of an AC voltage signal the frequency of which is proportional to the measured parameter. These sensors are very rugged and simple and have a very long service life. Their signal can be transmitted over long distances unaffected by influences that render resistive sensors unusable.

Two different methods are available for collecting and recording data from the installed sensors. For small number of sensors or if the recording is to be done at infrequent intervals, say every few months, a hand held indicator like Encardio-rite model EDI-51V indicator cum logger can be used to observe and store the sensor data. The EDI-51V vibrating wire indicator shows the measured parameter value directly in proper engineering units and can store the data so that it can be later on downloaded to a computer.

If the number of sensors is quite large or if the data is to be recorded very frequently it is more convenient to use a Data Acquisition System, known as DAS that can collect data unattended on its own. The Encardio rite model EDAS-10 automatic data acquisition system can collect and store data from a large number of sensors automatically at predetermined time intervals.

2. Purpose of instrumentation

2.1 To verify the design

The design of the structure is mainly aimed to provide a structure that will safely sustain its own weight and the imposed load within acceptable limits of deformation. This is achieved by working out and analysing the level of stress and deformation that would be induced in the structural member due to various imposed loads. These loads can be in the nature of a static dead load or due to vehicular and pedestrian traffic or imposed due to wind, temperature, earthquake, stream flow and support settlement.

Structural members are designed to be elastic in behaviour within certain limits under specified working conditions. The induced stresses consequently result in change of parameters like strain, deflection, load and inclination etc. These parameters can be easily measured and monitored by geotechnical instruments. Thus the designs are verified for changes in stress by using vibrating wire strain gages. Inclometers are used to verify the deflection in piers or wells. Displacement transducers and settlement devices are used to measure and monitor deflection, settlement, joint openings and movements. Load cells are used for balancing, distribution and monitoring of loads. Temperature for correlating data as a function of temperature variation is generally measured by means of a thermistor.

2.2 To verify the construction process

In order to ensure compliance with the specifications, tests must be carried out during the construction process. Instruments are used to carry out material tests, site trials and pre-concreting inspections during constructions. Temperature of concrete just before pouring and after curing is measured to control the heat of hydration. Center hole type load cells are frequently used to determine pre-stressing level of tendons. Some of the instrumentation employed to monitor construction process is specific to the method of construction used. For example, in one of the bridges instrumented by Encardio-rite, 150 tf center hole load cells were used to balance the segments on the piers during construction.

2.3 For performance monitoring and verification

For monitoring the performance and its verification, generally the same instruments as recommended for the verification of design are used. At times some instruments are added for monitoring of the actual dynamic behaviour of various structures but these require specialists for data analysis.

The measurement of actual deformation of the structure is sometimes hampered due to the practical difficulty of having a stable datum. Additional stable towers are therefore constructed from which measurement can be made with displacement sensors. Taut wires stretched between piers are also used as stable reference levels.

2.4 For monitoring condition of the bridge

It is essential to periodically monitor condition of the bridge to ensure its maintenance. The main factors affecting the performance is steel corrosion, degradation of concrete with age, undue settlement and change in the loading pattern due to increase in traffic with time. Sometimes, natural calamities like flood, earthquake or a cyclone may play havoc with the bridge, In all such cases, the instruments installed for design variation and performance monitoring give very important data on the state of the bridge. This is reflected in abnormal changes in strain, inclination and displacement values. Another parameter to be closely monitored is crack, if any, that might be formed at any time during the operation of the bridge. Vibrating wire or mechanical crack meters to measure crack openings and their variation with time can be installed at any time.

3. Type of instrumentation

Several types of sensors, transducers and other instruments based on well established technologies are available for instrumentation and monitoring of bridges. Types of physical parameters that are generally monitored in bridges are strain, stress, load, deflection, tilt, and temperature etc. Some of these are discussed in more detail below.

One of the most overlooked factor in bridge instrumentation is the actual process of installation of the sensors and instruments. Proper and successful instrumentation requires considerable skill and experience on the part of the personnel doing the installation. Generally installation should be entrusted to

personnel or organizations with considerable experience in this field. One should avoid the temptation of entrusting the installation work to people whose exposure is limited to a couple of weeks crash course or to treat the instrumentation project as a training ground for greenhorns. Any amount of theoretical knowledge is no substitute for years of on site installation experience. Failure analyses of instrumentation that had failed to perform satisfactorily have shown that a majority of the failures can be traced to faulty installation practice.

Strain

Short-term as well as long-term change in strain needs to be monitored. Short-term change in strain occurs over a period of hours whereas long-term changes in strain are those occurring over months or years. Short-term change in strain is generally caused by changes in dead and live loads, daily temperature cycles, or wind loading. Long-term changes are caused by seasonal temperature changes, creep, aging and shrinkage in concrete structures.

Encardio-rite vibrating wire strain gages are suitable for both short-term as well as long-term strain measurement. They are designed to have long-term stability, are robust for installation on site, and are provided with leads already attached. Encardio-rite model EDS-20V-E strain gage is suitable for embedment in concrete and model EDS-20V-S is suitable for surface mounting on steel sections and concrete structures. EDS-20V-SW is a waterproof version of EDS-20V-S.

Temperature

Temperature is measured to determine:

- Heat of hydration
- Temperature gradients
- Temperature corrections for other measurements

All Encardio-rite vibrating wire sensors excepting the vibrating wire temperature meter have a thermistor incorporated for temperature measurement. A separate temperature sensor is consequently not required wherever an Encardio-rite vibrating wire sensor is used. However, if only temperature is to be measured at a specific location, Encardio-rite model ETT-10TH resistance temperature probe can be used for surface mounting as well as embedment purposes. The ETT-10TH uses the same thermistor as is used in other Encardio-rite vibrating wire sensors. It is therefore compatible with the Encardio-rite model EDI-51V indicator and model EDS-10 automatic data acquisition system.

Deflection

Precise surveying equipment like a total station or an electronic level is used to measure the deflection at various points along the span of the bridge relative to some fixed reference points. Alternatively, a taut wire is stretched between two reference bolts fixed rigidly on two adjacent piers and the relative movement measured at locations along the span. On box girders with easy access to the inside, deflection relative to the wire can be measured on the underside of the deck inside the box. The tension in the wire is kept constant by using a pulley and weight at one end.

A typical scheme for measurement of vertical deflection using the Encardio-rite model EDJ-32V displacement sensor is illustrated in figure 1. The method requires a stable accessible reference location for each measurement. Reference towers have to be erected specially for this purpose.

When monitoring deflections, it is important to remember that temperature gradients can have a large effect on camber changes. Ideally, all deflection measurements should be taken just before sunrise when the temperature gradient is minimum.

Tilt

The Encardio-rite model EAN-12V vibrating wire tiltmeter with a range of $\pm 5^\circ$ is used to measure changes in the tilt of piers and foundation wells. In case deflection in two orthogonal directions is to be monitored at a particular location, it is always easy to use a second tiltmeter mounted at right angles to the first one. Tiltmeters can be mounted on either a horizontal or vertical surface. It can be read manually or with an automated data acquisition system. It may be used for both short-term as well as long-term measurement.

Pre-stressing force

The Encardio-rite model ELC-30V vibrating wire center hole load cell is an accurate method to determine the pre-stressing force prior to transfer. It can be positioned on strand at either the dead or the jacking end in the pre-stressing bed.

The ELC-30V load cell can also be used on the ends of unbonded post-tensioning tendons and stay cables to measure change in force with time. In case the "zero" reading of the load cell is to be verified at some time in the future, it can be done by using a lift-off procedure where the force on the load cell is removed by pulling on the end of the tendons and reacting directly against the concrete member.

Data acquisition

Two options are available for data acquisition

- The Encardio-rite model EDI-51V portable battery operated indicator is suitable for manually reading vibrating wire sensors to give display in engineering units like μ strain, kg/cm^2 , mm, kgf, tf, deg., $^{\circ}\text{C}$ etc. It also displays the temperature of the transducer directly in $^{\circ}\text{C}$ from a 3K thermistor incorporated in the sensor. The indicator has an internal non-volatile memory with provision of storing 720 sets of data in engineering units along with time, date and temperature. The data can be downloaded to a computer in comma delimited ASCII text format for further processing and analysis.
- The Encardio-rite model EDAS-10 automatic data acquisition system is suitable for continuous unattended data collection and monitoring. Scanning of data can be programmed at pre-determined rates through a multiplexer system. Data retrieval is possible through storage modules, PCMCIA cards, direct to computer, telephone or satellite links. The PC 208W datalogger support software allows telecommunications, programming and data processing functions. Graph mode allows real time visual graphical display of datalogger measurements that can be quickly conceptualised and checked for reliability by a bridge engineer.

4. Typical instrumentation scheme

The most important part for determining the actual instrumentation scheme is the bridge design itself. The design parameters, like maximum permitted stresses and deflections, and design assumptions like maximum loading, settlement, water level, wind load etc. must be fairly accurately known beforehand. The critical operating parameters and safety thresholds should be well defined. The exact type and number of sensors and instruments required for monitoring these parameters, their measurement range and actual location on bridge can then be determined from the design data. Unless the design parameters are known in advance simply putting in instruments serves no useful purpose. For then, there is no means of correlating the measured values with expected values or safe thresholds.

A typical instrumentation scheme for a bridge for automatic data monitoring is illustrated on the opposite page. The bill of materials is on the next page. A road bridge with four spans and three piers has been considered. The purpose is to give a general idea of the type of instrumentation required. Actual instrumentation required for a bridge will depend upon the site, the bridge design and factors like environmental conditions, life expectancy and the intensity of traffic to which it would be subjected.

The cabling network and junction cum switch boxes have not been shown in the drawings for the sake of simplicity. However, they are an essential and critical part of the system. A proper cable layout is necessary to allow monitoring of the data from all the sensors at one central point on the bridge or near one of the approach roads. Wherever this central point is located, cables from all the sensors will have to be properly routed to switch boxes located at the observation room/post. In case continuous data monitoring is planned, the observation room/post will also house the data acquisition system along with the necessary computer and printer.

A bridge with a longer length will need much more instrumentation. For a long bridge a minimum of two or three piers and spans must be instrumented. More piers/spans may have to be instrumented depending upon the site and design requirement. For example, piers suspected to be on weak foundations must definitely be instrumented.

Bridge design varies from bridge to bridge. Each bridge will have different instrumentation requirement. For example, in the instrumentation of a cable suspension bridge, the designer may in addition to other

parameters, like to monitor the cable tension with several center hole load cells or weldable strain gages. Many variations of instrumentation schemes are possible depending on the specific interest of the individual designer and safety requirements.

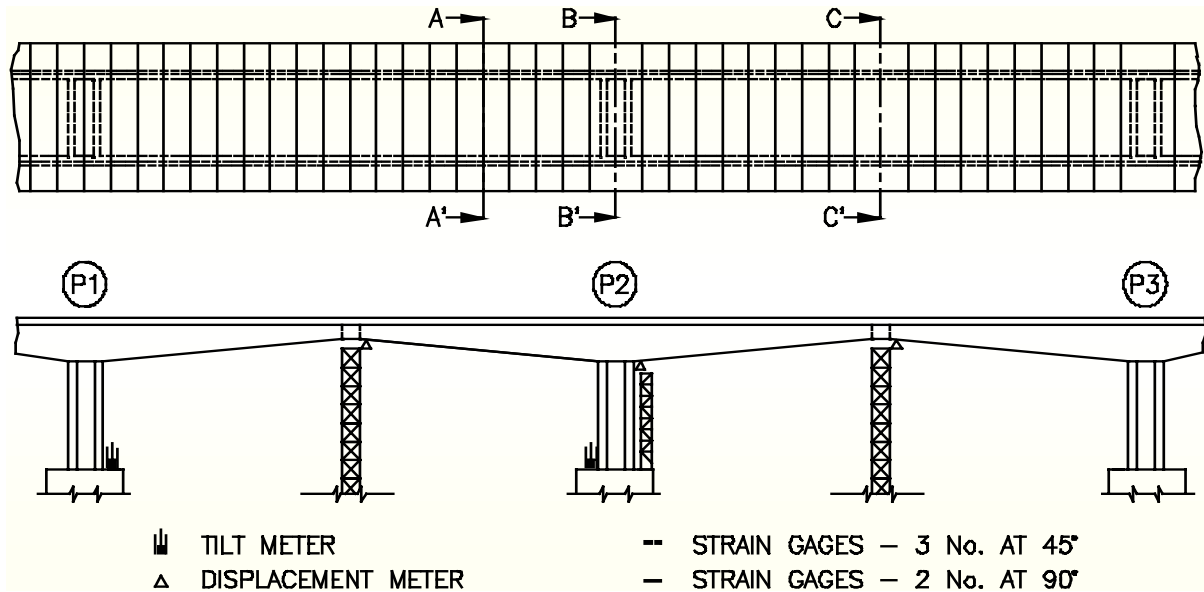
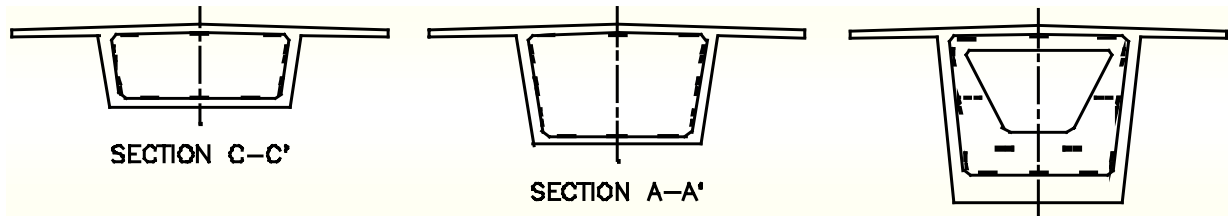
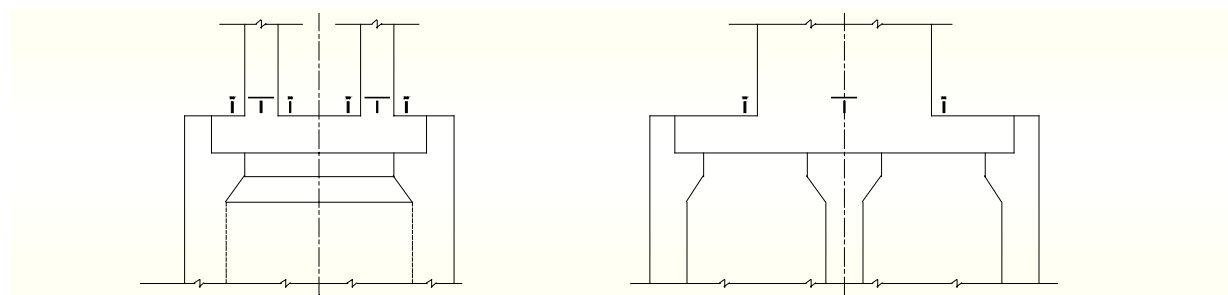

Figure 1



MOUNTING OF STRAIN/TEMPERATURE GAGES

Figure 2



MOUNTING OF WATER PROOF STRAIN/TEMPERATURE GAGES ON PIER P2

Figure 3

#	Description	Quantity
1.	EDS-20V-S strain gage (2 no at 90° to each other at each location)	36 no
2.	EDS-20V-S strain gage (3 no at 45° to each other at each location)	60 no
3.	EDJ-32V 30 mm displacement sensor with mounting brackets	3 no
4.	EAN-12V ± 5° tiltmeter (2 no at 90° to each other at each location)	4 no
5.	EDS-20V-SW strain gage	16 no
6.	ERC-16 four core cable from sensors to junction boxes	As required

#	Description	Quantity
7.	ESB-17-1 junction cum switch box suitable for input from 10 sensors, output through 4 core cable to indicator and 40 core cable to DAS	12 no
8.	EDI-51V vibrating wire indicator	2 no
9.	ERC-14 forty core jelly filled cable from junction boxes to DAS	As required
10.	EDAS-10 automatic data acquisition system suitable for 119 channels consisting of: CR-10X datalogger-2 no ESP-216 surge protector-15 no ER 416 16 channel multiplexer-8 no AVW4 V/W interface-3 no PC208W software- 1 no EBP-127Ah datalogger power supply -1 no 500 VA UPS with 20 minutes battery back up-1 no (user's scope) IBM compatible PC-1 no (user's scope) Colour ink jet printer-1 no (user's scope)	1 set

4.1 Wells

Well foundations are instrumented for measuring tilt. In figure 1, two tiltmeters each are mounted on the well cap of piers P1 and P2 at right angles to each other for monitoring the tilt along the river flow and perpendicular to it. Generally tiltmeters of range $\pm 5^\circ$ and accuracy of the order of 0.1° are suitable to measure the tilt within specified design values.

4.2 Well caps

In some cases one of the well caps is load tested to verify that it will withstand the live and dead design loads. The same strain gages are later on used for long term monitoring. It is best to select a well foundation where a tiltmeter is also installed. Generally two Encardio-rite model EDS-20V-SWP waterproof strain gages are mounted at right angles to each other at the surface of the well cap at several critical locations. Model studies or previous data is used to determine the locations where the strain gages are mounted. The well cap will have to be test loaded to verify the performance. This is usually done by grouting cable anchors in the ground around the pier, making a suitable frame and applying the load in conjunction with jacks. Measurement of strain during these tests also provides the calibration data for future monitoring.

Around 20 strain gages will be required for this test. These have not been included in the bill of materials.

4.3 Bridge pier

Encardio-rite model EDS-20V-SWP waterproof strain gages are used for measuring stress on the bridge pier. A typical installation is shown in figure 3. Two Encardio-rite model EDS-20V-SWP waterproof strain gages are mounted at right angles to each other in the middle of all the four sides of the piers to measure the vertical and lateral strain.

4.4 Bridge deck

It is essential to monitor the stresses induced in different sections of the bridge deck. Figure 2 shows three sections of the deck at which induced stresses are measured. These are at the central pier and quarter & half spans at either sides of the central pier. Encardio-rite model EDS-20-V-S strain gages are bonded on the inner surface of the deck. These strain gages are not waterproof as they are quite well protected from the outside environment. At the top and bottom surface of the deck, two strain gages are mounted at right angles to each other at each location for monitoring stress along the river flow and perpendicular to it. On the sidewalls, three strain gages are mounted in rosette configuration at 45° to each other at each location for monitoring vertical, horizontal and shear stress respectively.

4.5 Deck and pier displacement

Deck displacement is usually measured at the mid-span. In case of long spans, deck displacement may be additionally measured at quarter span also. For this purpose, stable reference towers are erected at these points. Displacement of the pier top measured in respect to the well cap helps in correlating the data obtained from the strain gages mounted in the vertical direction on the piers (figure 3). The Encardio-rite model EDJ-34V displacement transducer with a range of 25 mm is most suitable for this measurement. It is an electron beam welded, hermetically sealed sensor with a vacuum of 1/1000 Torr inside it. Figure 1 shows displacement transducers at three locations, two at mid-span and one at top of the central pier.

4.6 Temperature measurement

Temperature is measured to determine temperature gradients and for temperature corrections to be applied for other measurements. Temperature differential between the various portions of the deck induces stress. This may be due to the apparent movement of the Sun in the sky or directional rain or snowfall. Therefore temperatures at the inside of the bridge deck at all the four surfaces must be monitored. All Encardio-rite vibrating wire strain gages have in-built temperature sensors. Separate temperature sensors are consequently not required. However if independent temperature sensors have to be mounted at any particular locations the Encardio-rite model ETT-10TH surface mountable temperature probe must be used. It is a thermistor base sensor and can be used with the Encardio-rite model EDI-51V indicator for taking and storing the temperature data with time and date.

5. Case study: Instrumentation of 2nd Narmada Bridge

5.1 An overview of instrumentation of the bridge

We are considering here the instrumentation of 2nd Narmada Bridge at NH no. 8 at Bharuch, Gujarat. This bridge has 14 piers and a span of 1.4 km. It is of segmental balanced cantilever type. A comprehensive instrumentation program was carried out by the chief civil contractor L&T- ECC Construction Division following the guidelines given by the design consultants DAR of UK. L&T need not look far for its requirement of civil engineering instruments and it chose all the instruments suitable for their application from our comprehensive range of geotechnical, geophysical and groundwater instruments. The bridge was instrumented to assess its performance during the pre-commissioning load testing and long term monitoring, as per the following scheme:

- Strain gages (bill of material item # 1,2) were bonded on the inner surface of the bridge segments located at the half span, quarter span and at the top of the pier, to measure the stresses induced in these during the load testing and during the normal use of the bridge i.e. in course of the long term monitoring program.
- Displacement sensors (bill of material item # 3) were mounted beneath the deck at 5 locations and at the top of the pier P3 (figure 4) to measure the deck and pier deflections respectively. Rigid towers were erected for mounting the same.
- Encardio-rite model ETT-10TH surface mountable temperature probe were bonded on the inner surface of the bridge segments located at the half span, quarter span and at the top of the pier to measure temperature difference between the walls of the segments. The effect of this temperature difference on the stresses induced in the segments will be taken into consideration during the monitoring.
- Waterproof strain gages (bill of material item # 5) were mounted at the foot of the pier to measure the bending stresses induced there during the load testing as well as during the long term monitoring.
- Tilt meters (bill of material item # 4) were mounted in two directions: along the flow of the river and perpendicular to it, on the well cap of pier P12 for long term monitoring of well tilt.
- All the cabling was routed along the inner walls of the segments and terminated in junction cum switch boxes (bill of material item # 7) mounted on the lateral diaphragm walls of segment at the top of the pier P3. This facilitated monitoring of all the sensors from one central location. Vibrating wire indicator cum data logger (bill of material item # 8) was used to monitor and store the readings, which were downloaded in a PC from time to time for further analysis.

5.2 Observations

The bridge was load tested as per four load cases during which gabion crates filled with sand bags were kept over the span of the bridge up to a certain length at certain distance from the nearby pier, to form uniformly distributed load (UDL). The distance of CG of the load from the SOL of bridge also differed from load case to load case.

Let us consider load case-I (figure 4) and readings of strain gages mounted on the inner walls of segment SC8 (at quarter span between piers P4 and P3; figure 5) at the end of 24hr. period of this load case. Under this load case a UDL of 5.81 t/m was distributed over a span of 50 m, whereby the center of this load span coincided with the middle of bridge span between piers P4 and P3. C.G of the test load was at 407 mm, towards the U/S side from the S.O.L. of bridge. A chart depicting actual strain values and theoretical/predicted values for the respective strain gages is shown in figure 6 below. The theoretical values were found using bridge design software and simulating the above mentioned load case in the same, by the design consultants.

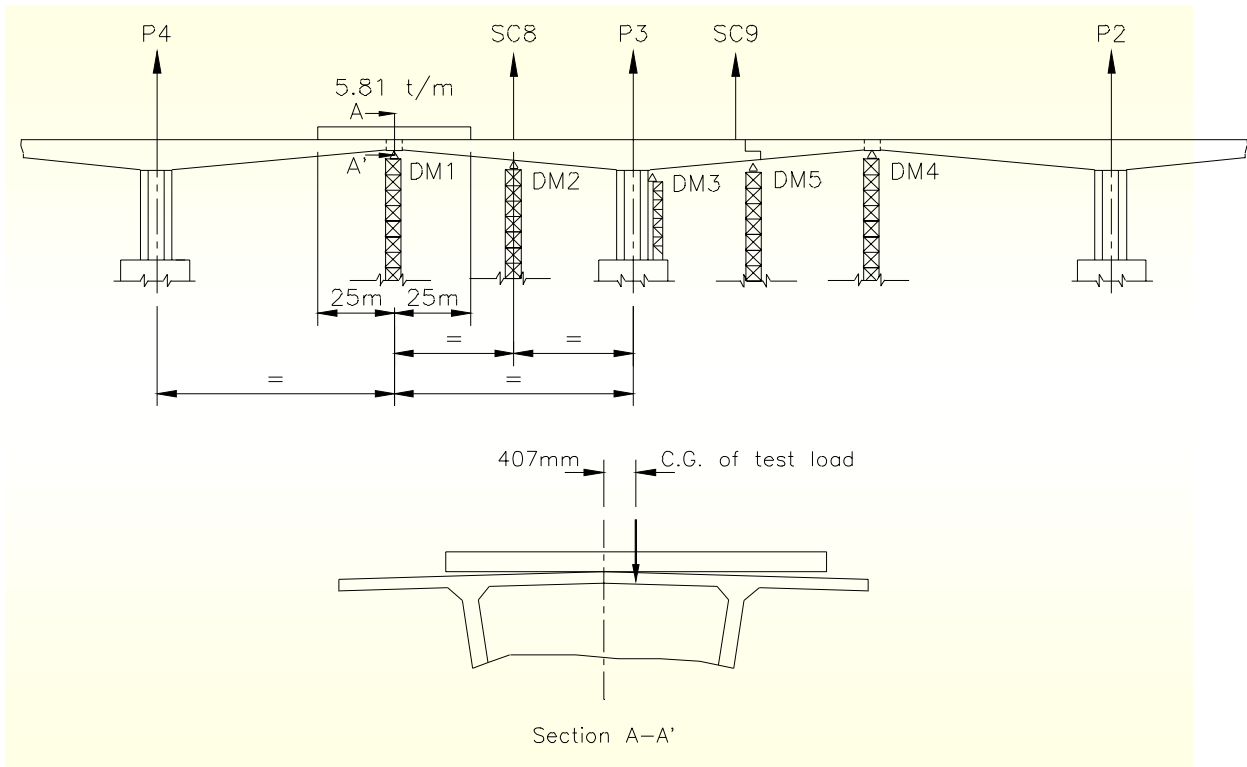

Figure 4 Load case 1 and location of displacement meters

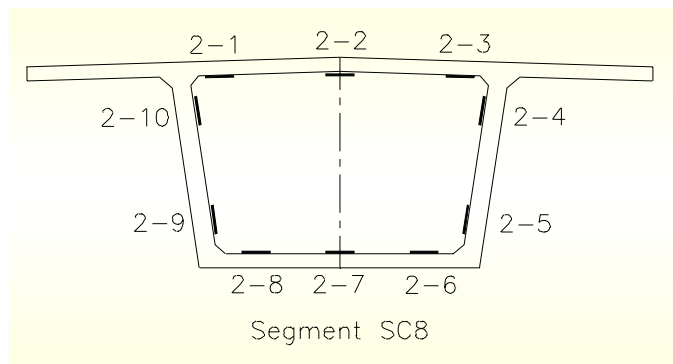

Figure 5 Location of strain gages inside segment SC-8 (looking in the direction of increasing station i.e. from P2 to P3)

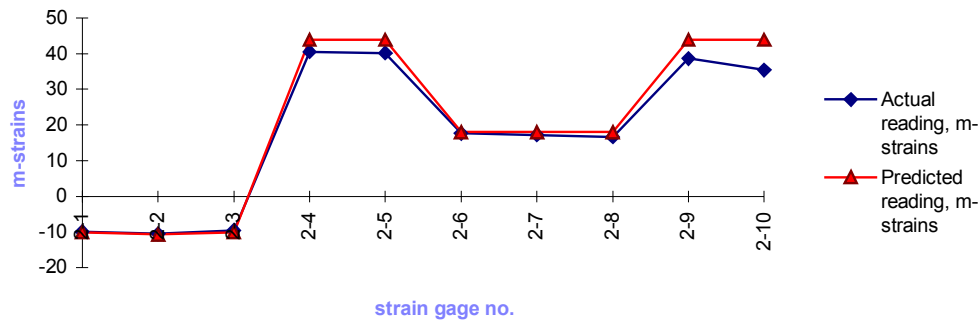

Figure 6 Actual v/s predicted readings for segment SC8, load case 1

In the chart shown in figure 7, actual values of deck/pier deflection at the end of 24 hr period of load case 1 are plotted along with predicted deck/pier deflections values, for the 5 locations (figure 4). A negative deflection means deflection in the upward direction.

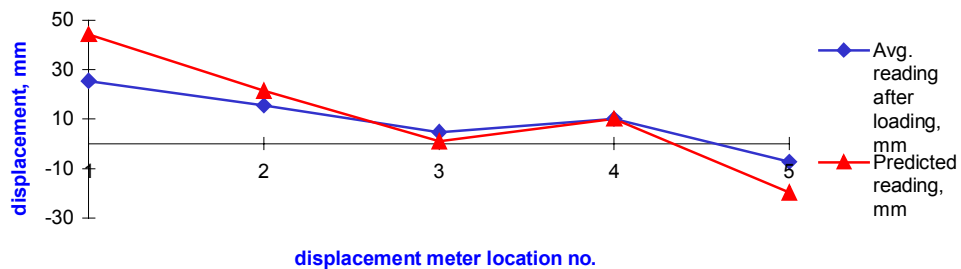

Figure 7 Actual v/s predicted deflections at various locations, load case 1

5.3 Conclusions

From figure 6 we also get a picture of stress distribution on the four walls of the segment SC8. The stress is tensile in nature at the roof and compressive at the walls and the floor. The stress on the segment floor is almost half of what it is on the two walls, which is quite obvious. Also we see that the curve for actual readings closely follow that for predicted readings. This tells that the bridge is constructed to very close tolerances to the design parameters, correct construction practices were adapted and high quality material was used.

Figure 7 shows that in most of the locations (excepting location 3) the actual deflections are much less than the predicted ones and that too during the maximum design moments simulated under load case 1. Here the performance of the structure exceeded the expectations.

The results were more or less same for the other three load cases and bridge was deemed suitable for commissioning on the basis of above results.